

POWER CORD 2300 LONG OUTSIDE
(PLUG WITH EARTH WIRE)

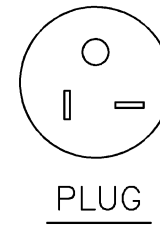

DIGITAL THERMOMETER

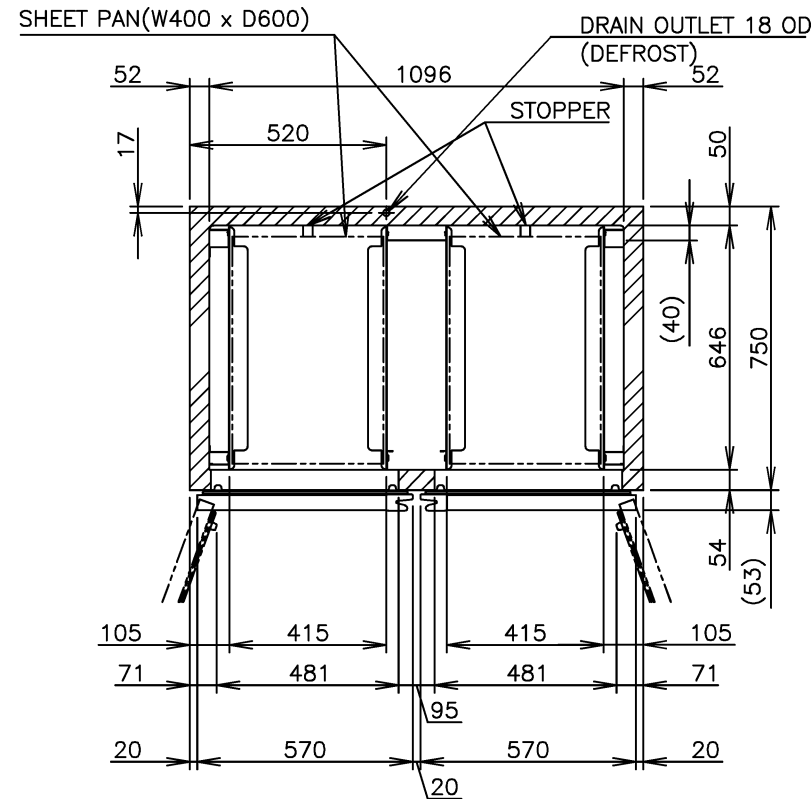
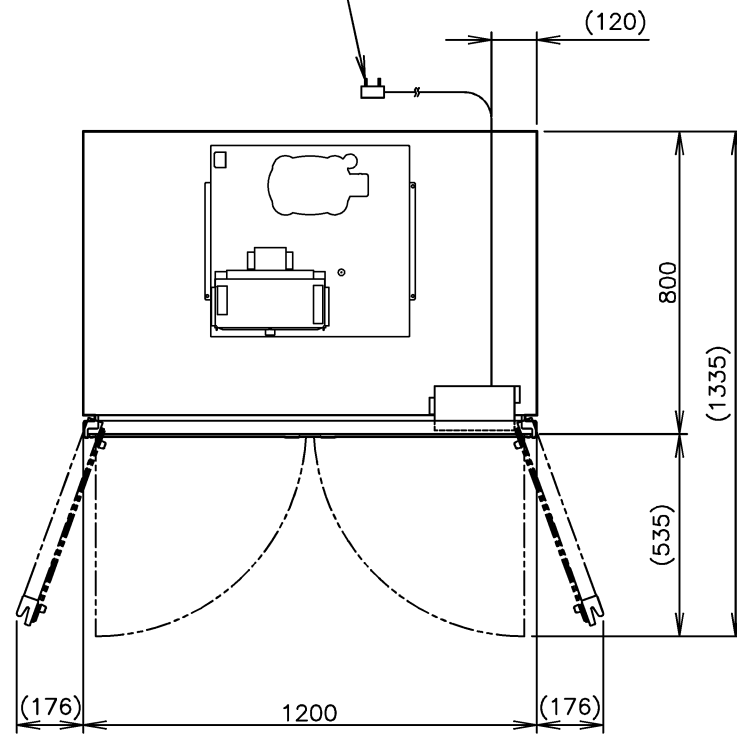
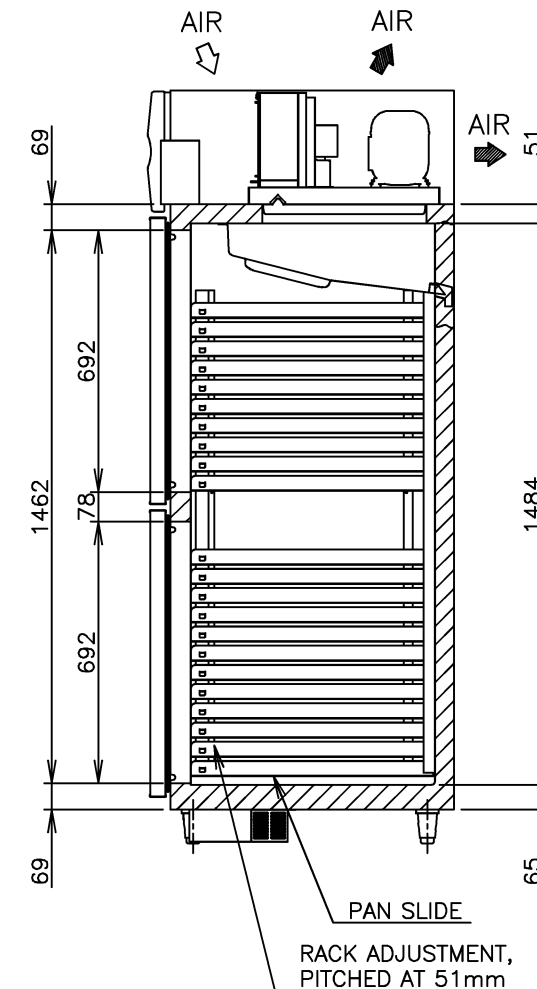
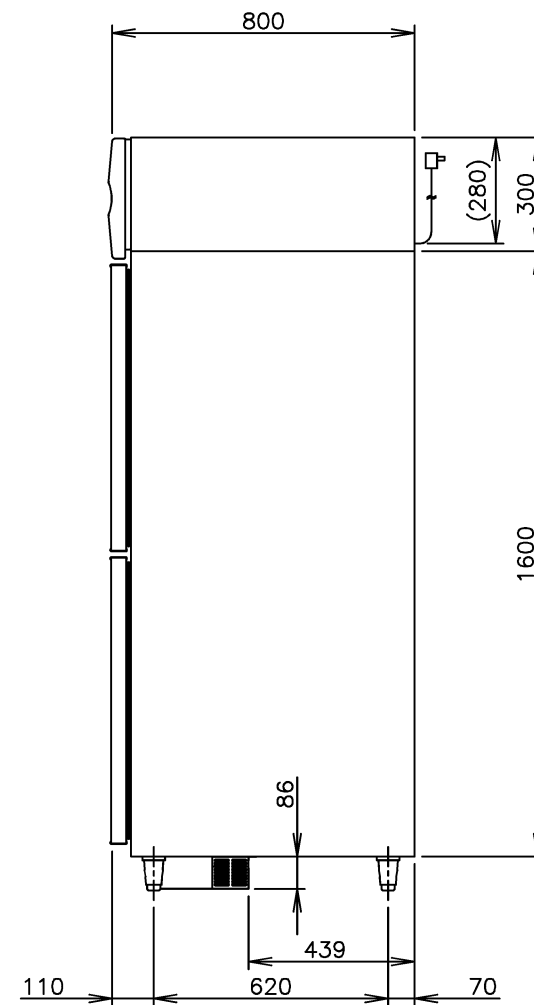
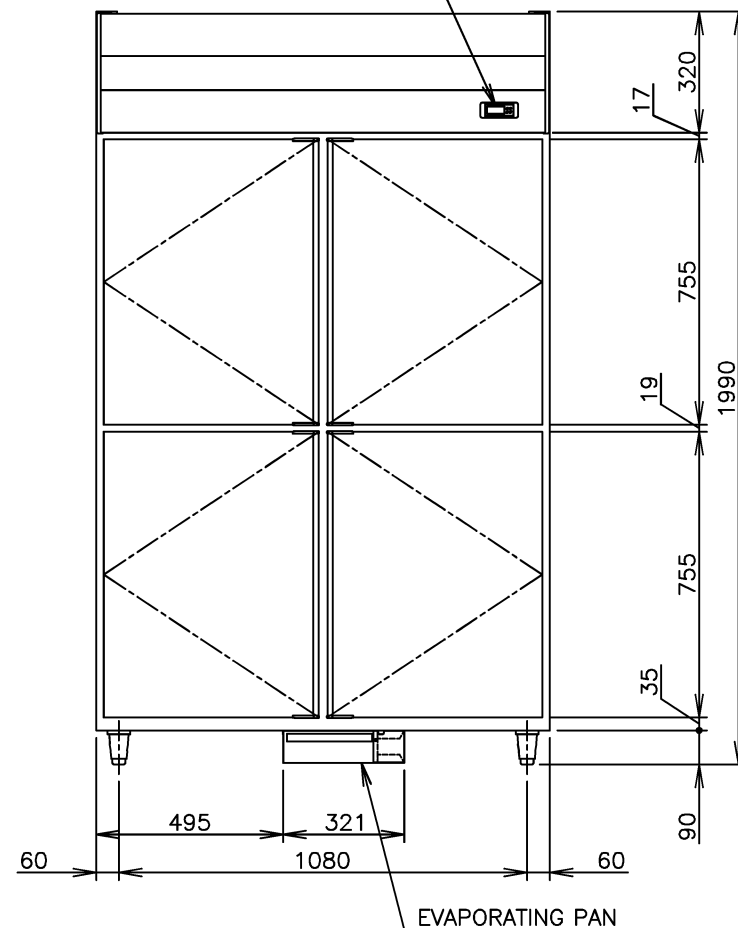

ITEM	Hoshizaki Reach-in Refrigerator
MODEL	HR-128MA-T
POWER SUPPLY	1 Phase 220V ~ 60Hz Capacity: 0.97kVA (4.39A)
AMPERAGE	Rated: 3.60A Starting: 13.1A
ELECTRIC CONSUMPTION	333W Heater: 408W Defrost: 408W
HEAT REJECTION	*W
POWER CORD	2.3m (Plug with Earth Wire)
EFFECTIVE CAPACITY	1053L
OUTSIDE DIMENSIONS	1200mm(W) x 800mm(D) x 1990(-2020)mm(H)
INSIDE DIMENSIONS	1096mm(W) x 646mm(D) x 1484mm(H)
EXTERIOR	Stainless Steel, Galvanized Steel(Top, Rear, Bottom)
INTERIOR	Stainless Steel, ABS Plastic(Door)
INSULATION	Polyurethane Foam
INSULATION FOAM BLOWING AGENT	Cyclopentane
REFRIGERATION SYSTEM	Forced Air Circulation
DEFROST SYSTEM	Heater
COMPRESSOR	Hermetic
CONDENSER	Wire and Tube type, Air-cooled
EVAPORATOR	Fin and Tube type
REFRIGERANT	R134a
TEMPERATURE CONTROL	Microprocessor (Digital Temp. Indication) Adjustable from -6 to 12° C
DEFROST CONTROL	Microprocessor
ELECTRIC CIRCUIT PROTECTION	Earth Wire, Circuit Breaker
REFRIGERANT CIRCUIT PROTECTION	Motor Protector (Auto-reset)
LEG	Plastic Adjustable from 90 to 120mm
SHELF	Tray Shelf(Upper 10tiers, Lower 12tiers)
WEIGHT	144kg (Gross 176kg)
PACKAGE	Carton (Wooden Pallet) 1260mm(W) x 900mm(D) x 2075mm(H)
ACCESSORIES	Drain Hose x 1, Drain Pan x 1
OPERATING CONDITIONS	Ambient Temperature: 5 - 43° C Voltage Range: Rated Voltage ±6%

*We reserve the right to make changes in specifications and design without prior notice.

1. Install the product properly in accordance with the instructions on location, water supply/drain connections and electrical connections stated in the instruction and installation manuals provided.
Allow 10mm extra space at the installation site to meet any installation requirements (additional spacing is also required for proper air flow and pipe connections).
2. The heat rejection is based on the reached pulldown temperature at ambient temperature of 35° C.
3. Product Code: R591-D202 (HTW)

*CUSTOMIZED
TRAY SHELF(STOPPER)
SHEET PAN(W400 x D600)
PITCHED AT 51mm
(MAX : UPPER 10TIERS, LOWER 12TIERS)

HOSHIZAKI REACH-IN REFRIGERATOR HR-128MA-T

APPROVED NAGASE	CHECKED NAGASE	DESIGNED ZHOU	DRAWN ZHOU	SCALE 1/20	TRIGONOMETRY
*	*	△	*	DATE 2020.10.23	DRAWING NO. D29352
APPROVED	DESIGNED	SYMBOL	DATE		SYMBOL