

PACKAGE	Carton 710mm(W) x 715mm(D) x 996mm(H)
ACCESSORIES	Instruction Manual, Scoop, Leg
OPTION	UV-LED, Fully Automated Cleaning kit
OPERATION CONDITION	Ambient Temp.: 7-38° C, Water Supply Temp.: 7-32° C Water Supply Pressure: 0.07-0.8MPa(0.7-8bar) Voltage Range: ± 6%

- *We reserve the right to make changes in specifications and design without prior notice.
1. Install the product properly in accordance with the instructions on location, water supply/drain connections and electrical connections stated in the instruction and installation manuals provided.
 2. The ice production depends on the ambient and water temperatures. Refer to the instruction manual.
 3. Standard Model
Product Code: F159-C191
 4. Fully Automated Cleaning Model
Model: KM-60C-W
Product Code: F159-C291
WEIGHT : 48kg(Gross 60kg)

ITEM	Hoshizaki Crescent Ice Maker (Self-Contained Type)
MODEL	KM-60C
POWER SUPPLY	1 PHASE 110V 60Hz Capacity: Min. 1.11kVA (10.1A)
AMPERAGE	5.4A(AT. 32° C, WT. 21° C) Starting: 37.0A
ELECTRIC CONSUMPTION	Rated Motor: 377W (Power factor: 63%)
ICE PRODUCTION PER 24h	Approx. 65kg/d(AT. 10° C, WT. 10° C) Approx. 58kg/d(AT. 21° C, WT. 15° C) Approx. 50kg/d(AT. 32° C, WT. 21° C)
WATER CONSUMPTION PER 24h	Approx. 0.33m³/d(AT. 10° C, WT. 10° C) Approx. 0.32m³/d(AT. 21° C, WT. 15° C) Approx. 0.20m³/d(AT. 32° C, WT. 21° C)
ELECTRIC CONSUMPTION PER 100kg ICE	17.0kWh/100kg(AT.32° C,WT.21° C)
WATER CONSUMPTION PER 100kg ICE	0.39m³ /100kg(AT.32° C,WT.21° C)
SHAPE OF ICE	Crescent Cube
FREEZE CYCLE TIME	Approx. 26Min(AT. 21° C, WT. 15° C)
ICE PRODUCTION PER CYCLE	Approx. 1.00kg / 110pcs(AT. 21° C, WT. 15° C)
MAX STORAGE CAPACITY	Approx. 23kg(Bin Cont Setting Approx. 19kg)
OUTSIDE DIMENSIONS	605mm(W) x 610mm(D) x 988(982-1005)mm(H)
EXTERIOR	Stainless Steel, Galvanized Steel(Rear),Plastic(Louver)
INSULATION	Polyurethane Foam
INSULATION FOAM BLOWING AGENT	Cyclopentane
CONNECTIONS-ELECTRIC	Y-type Connection(with Plug)
CONNECTIONS-WATER SUPPLY	Inlet G3/4"(connected at rear side)
CONNECTIONS-DRAIN	Outlet φ 24.5(connected at rear side)
ICE MAKING SYSTEM	Vertical Evaporator with water flow on both sides
HARVESTING SYSTEM	Water Supply Harvest Cycle and Hot Gas Defrost
COMPRESSOR	Hermetic
CONDENSER	Air-cooled, Fin and Tube type
HEAT REJECTION	950W(817kcal/h) (AT.32° C, WT.21° C)
EVAPORATOR	Vertical type, Stainless Steel and Copper
REFRIGERANT CONTROL	Capillary Tube
REFRIGERANT CHARGE	R134a/210g
ICE MAKING CONTROL SYSTEM	Float Switch
HARVESTING CONTROL SYSTEM	Hot Gas and Water, Thermistor and Timer
ICE MAKING WATER CONTROL SYSTEM	Timer Controlled, Overflow Pipe
BIN CONTROL SYSTEM	Mechanical Level Switch with Delay
ELECTRICAL PROTECTION	Class I Appliance, 5A Fuse
COMPRESSOR PROTECTION	Auto-reset Overload Protector(Internal)
LOW WATER PROTECTION	Float Switch
ICE MAKER PROTECTION	Interlock by Controller Board
WEIGHT	46kg(Gross 58kg)

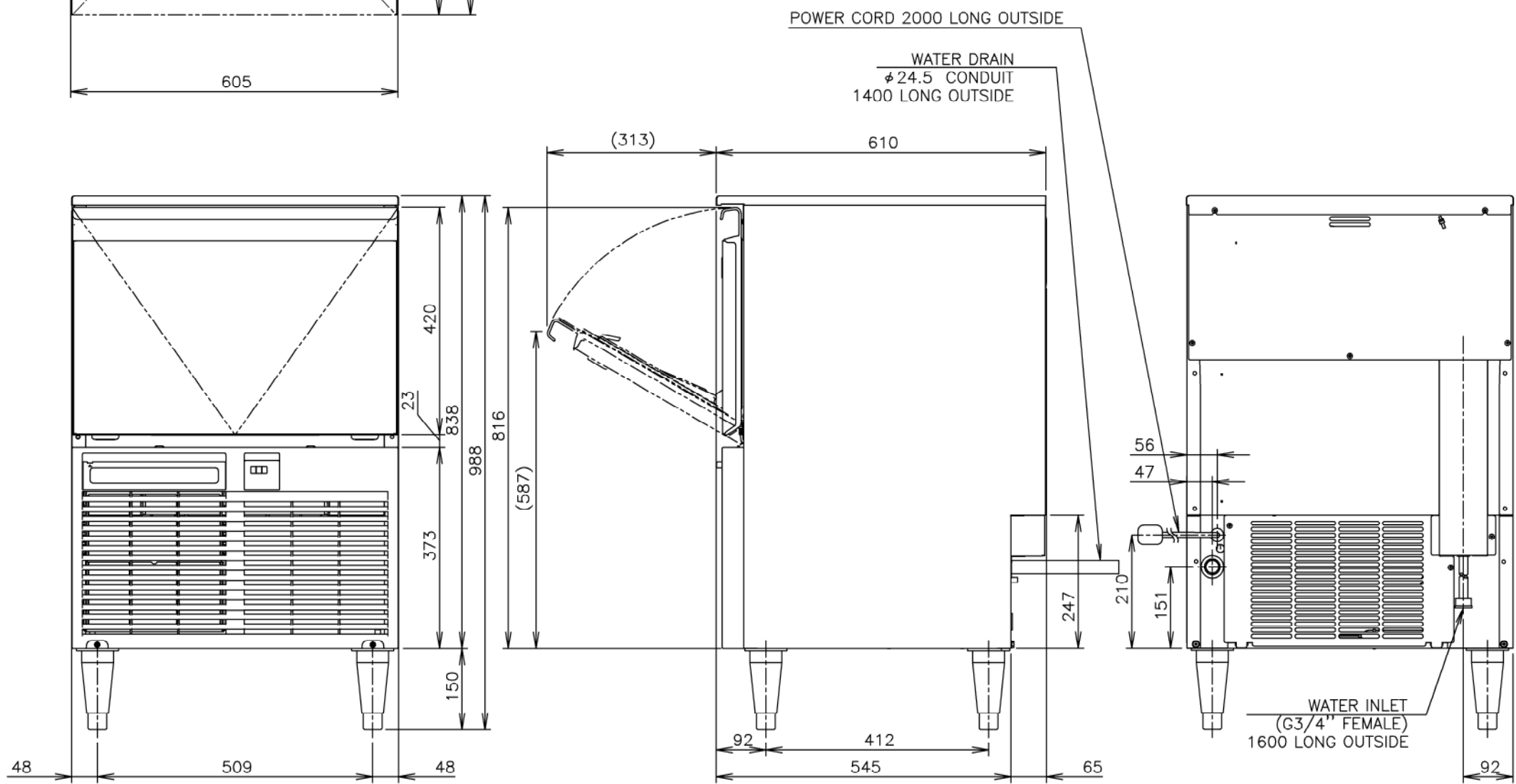

HOSHIZAKI CRESCENT ICE MAKER(SELF-CONTAINED TYPE) KM-60C(for Taiwan)

APPROVED KONDO	CHECKED UEDA	DESIGNED KOSHI	DRAWN OHASHI	SCALE 1/10	TRIGONOMETRY
* APPROVED	* DESIGNED	△ SYMBOL	***** DATE	DATE 2023.01.18	DRAWING NO. D35098